



To prevent accidents arising from the misuse of this controller, please ensure the operator receives this manual.

## **Safety precautions (Be sure to read these precautions before using our products.)**

The safety precautions are classified into categories: "Warning" and "Caution". Depending on circumstances, procedures indicated by  Caution may result in serious consequences, so be sure to follow the directions for usage.

 **Warning** Procedures which may lead to dangerous conditions and cause death or serious injury, if not carried out properly.

 **Caution** Procedures which may lead to dangerous conditions and cause superficial to medium injury or physical damage or may degrade or damage the product, if not carried out properly.

### **Warning**

- To prevent an electric shock or fire, only our or other qualified service personnel may handle the inner assembly.
- To prevent an electric shock, fire or damage to the instrument, parts replacement may only be undertaken by our or other qualified service personnel.

### **Safety precautions**

- To ensure safe and correct use, thoroughly read and understand this manual before using this instrument.
- This instrument is intended to be used for industrial machinery, machine tools and measuring equipment. Verify correct usage after purpose-of-use consultation with our agency or main office. (Never use this instrument for medical purposes with which human lives are involved.)
- External protection devices such as protection equipment against excessive temperature rise, etc. must be installed, as malfunction of this product could result in serious damage to the system or injury to personnel. Proper periodic maintenance is also required.
- This instrument must be used under the conditions and environment described in this manual. Shinko Technos Co., Ltd. does not accept liability for any injury, loss of life or damage occurring due to the instrument being used under conditions not otherwise stated in this manual.

#### **Caution with respect to Export Trade Control Ordinance**

To avoid this instrument from being used as a component in, or as being utilized in the manufacture of weapons of mass destruction (i.e. military applications, military equipment, etc.), please investigate the end users and the final use of this instrument. In the case of resale, ensure that this instrument is not illegally exported.

### **Caution**

- This instrument should be used according to the specifications described in the manual. If it is not used according to the specifications, it may malfunction or cause a fire.
- Be sure to follow the warnings, cautions and notices. If they are not observed, serious injury or malfunction may occur.
- Specifications of the BCD2 and the contents of this instruction manual are subject to change without notice.
- Measures must be taken to ensure that the operator cannot touch power terminals or other high voltage sections.
- Be sure to turn the power supply to the instrument OFF before cleaning this instrument.
- Use a soft, dry cloth when cleaning the instrument.  
(Alcohol based substances may tarnish or deface the unit.)
- As the display section is vulnerable, do not strike or scratch it with a hard object.
- Any unauthorized transfer or copying of this document, in part or in whole, is prohibited.
- Shinko Technos Co., Ltd. is not liable for any damages or secondary damages incurred as a result of using this product, including any indirect damages.

# 1. Model

## 1.1 Model

BCD2	R	<input type="checkbox"/>	0	-	<input type="checkbox"/>	<input type="checkbox"/>	
OUT1	R						Limit control output (Relay contact: 1a)
Power supply voltage		0					100 to 240 V AC (Standard)
		1					24 V AC/DC
Input			0				Multi-range (*1)
Option			0				No option 1 needed.
			1		EV2		A2 output (Alarm type can be selected by keypad) (*2)
				0			No option 2 needed.
				6	C5		Serial communication (RS-485)

(\*1) Thermocouple, RTD, Direct current and DC voltage can be selected by keypad.

(\*2) Alarm actions (9 types and No alarm action) and Energized/De-energized can be selected by keypad.

## 1.2 How to read the model label

Model labels are attached to the case and the inner assembly.

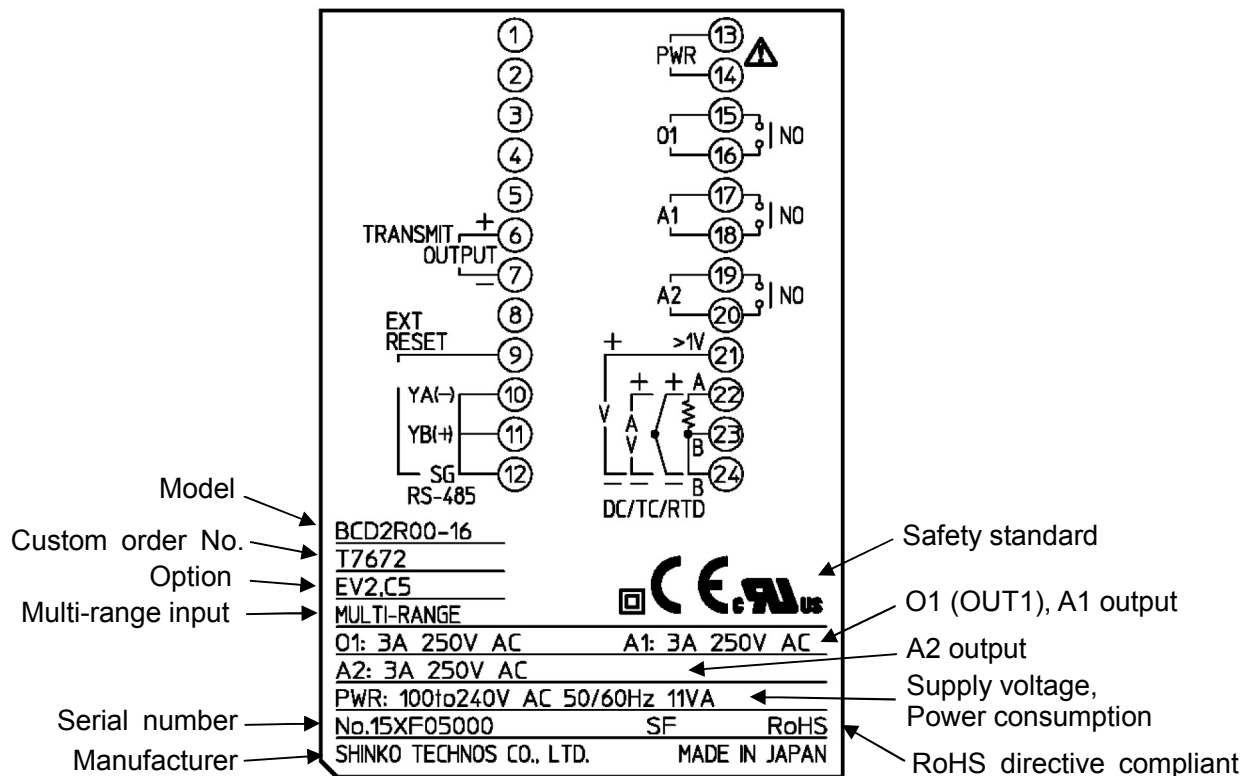

## 2. Name and functions of the sections

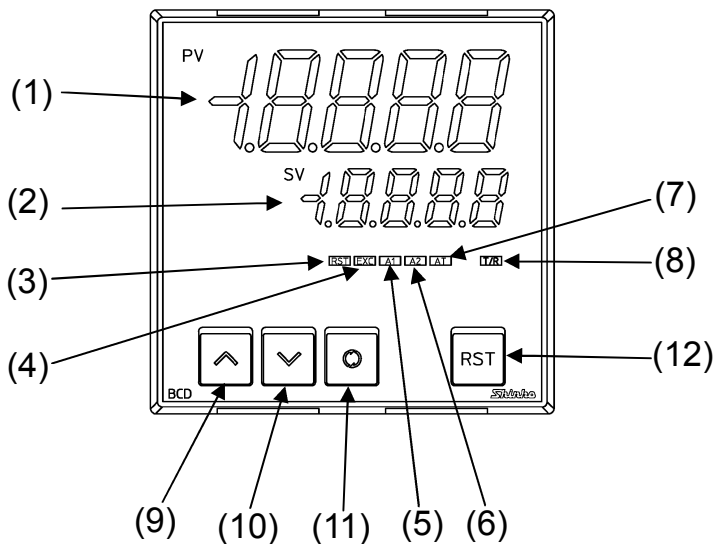

(Fig. 2-1)

### (1) PV Display

Indicates the PV (process variable) with a red LED.

Indicates setting item characters during the setting mode.

### (2) SV Display

Indicates the SV (desired value) with a green LED.

Indicates set (selected) value during the setting mode.

### (3) RST (RESET) indicator

Lights when OUT1 NO contact (terminals 15 and 16) is OFF with a green LED.

### (4) EXC (EXCEEDED) indicator

High limit action: The yellow LED lights when  $PV \geq SV$ .

Low limit action: The yellow LED lights when  $PV \leq SV$ .

### (5) A1 indicator

When Alarm 1 output is ON, the red LED lights.

### (6) A2 indicator

When Alarm 2 output (EV2 option) is ON, the red LED lights.

### (7) AUTO indicator

The yellow LED lights for Auto limit control action.

### (8) T/R indicator

The yellow LED lights during Serial communication TX output (transmitting) (C5 option).

### (9) UP key (⤴)

Increases the numerical value, switches the setting item during the setting mode.

### (10) DOWN key (⤵)

Decreases the numerical value, switches the setting item during the setting mode.

### (11) MODE key (⊙)

Switches setting mode, and registers the set (selected) value.

### (12) RESET key (RST)

Resets OUT1 (limit control output).

## Notice

When setting the specifications and functions of this controller, connect terminals 2 and 3 for power source first, then set them referring to Section "5. Settings" before performing "3. Mounting to the control panel" and "4. Wiring".

# 3. Mounting to the control panel

## 3.1 Site selection



### Caution

- Use within the following temperature and humidity ranges.  
Temperature: -10 to 55°C (14 to 131°F), Humidity: 35 to 85 %RH (No condensation, no icing)
- When this unit is installed through the control panel, the ambient temperature of this unit – not the ambient temperature of the control panel – must be kept to under 55°C (131°F). Otherwise the life of electronic components (especially electrolytic capacitors) will be shortened.

**This instrument is intended to be used under the following environmental conditions (IEC61010-1): Overvoltage category II, Pollution degree 2**

Ensure the mounting location corresponds to the following conditions:

- A minimum of dust, and an absence of corrosive gases
- No flammable, explosive gases
- Few mechanical vibrations or shocks
- No exposure to direct sunlight, an ambient temperature of -10 to 55°C (14 to 131°F) that does not change rapidly
- An ambient non-condensing humidity of 35 to 85 %RH
- No large capacity electromagnetic switches or cables through which large current flows
- No water, oil or chemicals or where the vapors of these substances can come into direct contact with the controller

## 3.2 External dimensions (Scale: mm)

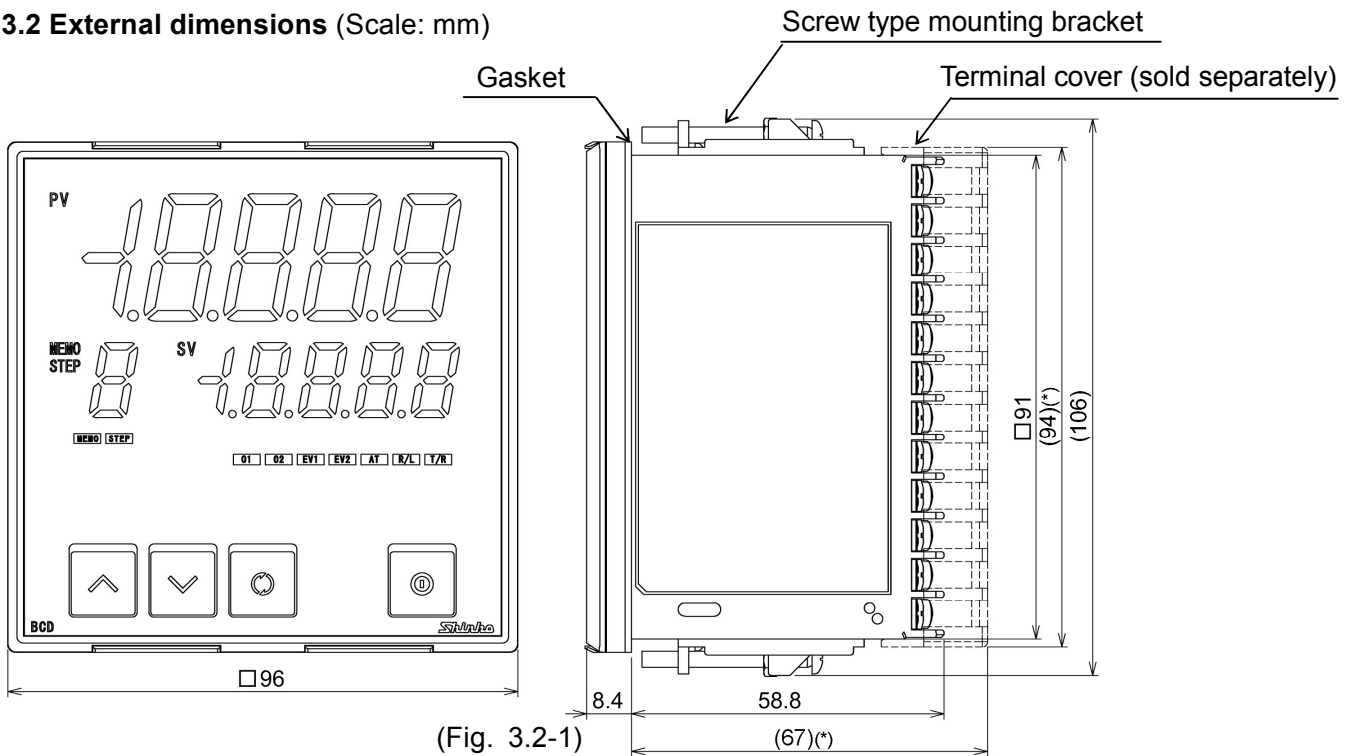

(Fig. 3.2-1)

## 3.3 Panel cutout (Scale: mm)

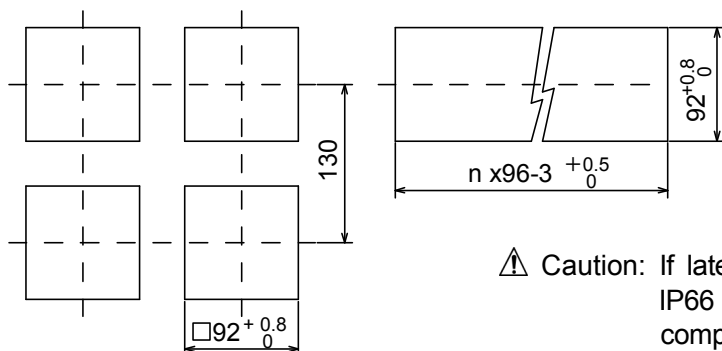

Lateral close mounting  
n: Number of units mounted

**Caution:** If lateral close mounting is used for the controller, IP66 specification (Dust-proof/Drip-proof) may be compromised, and all warranties will be invalidated.

(Fig. 3.3-1)



## Caution

As the case is made of resin, do not use excessive force while screwing in the mounting bracket, or the case or screw type mounting bracket could be damaged. The torque is approximately 0.1 N·m.

### 3.4 Mounting

Mount the controller vertically to the flat, rigid panel to ensure it adheres to the Drip-proof/Dust-proof specification (IP66).

If the lateral close mounting is used for the controller, IP66 specification (Drip-proof/Dust-proof) may be compromised, and all warranties will be invalidated.

Mountable panel thickness: 1 to 7 mm

(1) Insert the controller from the front side of the control panel.

If the Drip-proof/Dust-proof specification (IP66) is not necessary, the gasket may be removed (please keep in mind the warranty is void if gasket is removed).

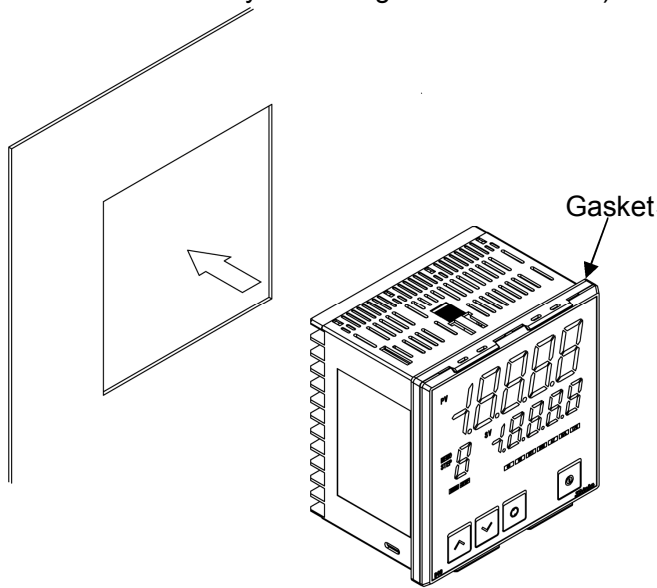

(Fig. 3.4-1)

(2) Attach the mounting brackets by the holes at the top and bottom of the case, and secure the controller in place with the screws. The torque is approximately 0.1 N·m.

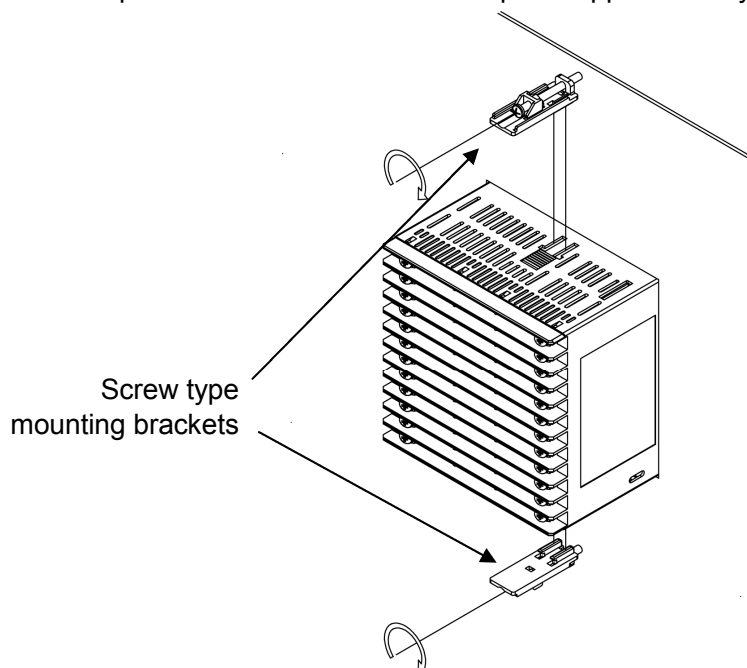

(Fig. 3.4-2)

# 4. Wiring

## ⚠ Warning

Turn the power supply to the instrument off before wiring or checking.  
Working on or touching the terminal with the power switched on may result in severe injury or death due to electrical shock.

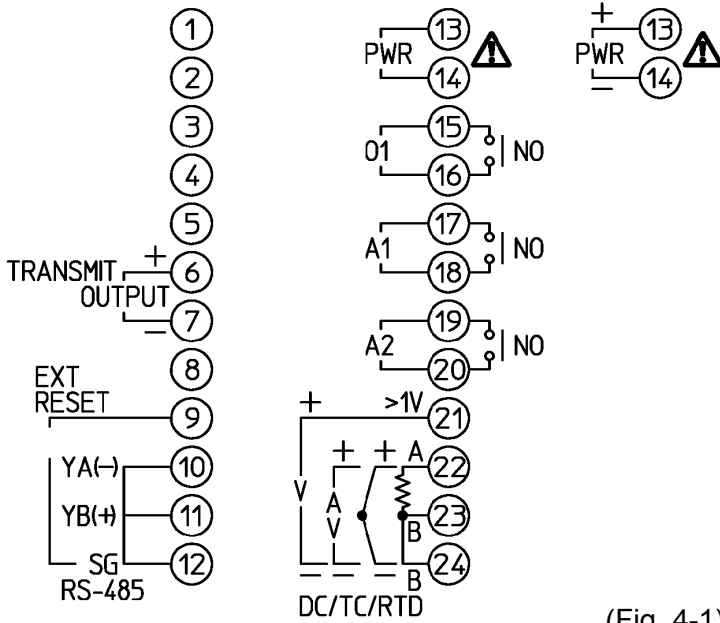

- TRANSMIT OUTPUT: Transmission output
- EXT.RESET: External reset input
- RS-485: Serial communication (C5 option)
- PWR: Power supply
- O1: Limit control output (OUT1)
- A1: Alarm 1 (A1) output
- A2: Alarm 2 (A2) output (EV2 option)
- DC: Direct current, DC voltage input
- TC: Thermocouple input
- RTD: Resistance temperature detector input

(Fig. 4-1)

## ⚠ Notice

- The terminal block of the BCD2 is designed to be wired from the left side. The lead wire must be inserted from the left side of the terminal, and fastened by the terminal screw.
- Use a thermocouple and compensating lead wire that correspond to the sensor input specification of this controller.
- Use the 3-wire RTD which corresponds to the input specification of this controller.
- This controller does not have built-in power switch, circuit breaker and fuse. Therefore, it is necessary to install a power switch, circuit breaker and fuse in the circuit near the external controller. (Recommended fuse: Time-lag fuse, rated voltage 250 V AC, rated current 2 A)
- For a 24 V AC/DC power source, do not confuse polarity when using direct current (DC).
- For the OUT1 (Limit control output terminals 15-16), externally use a relay according to the capacity of the load to protect the built-in relay contact.
- When wiring, keep input wires (thermocouple, RTD, etc.) away from AC sources or load wires to avoid external interference.
- Do not apply a commercial power source to the sensor connected to the input terminal nor allow the power source to come into contact with the sensor.

### Lead wire solderless terminal

Use a solderless terminal with an insulation sleeve in which an M3 screw fits as shown below. The torque is approximately 0.63 N•m.

Solderless terminal	Manufacturer	Model	Tightening torque
Y-type	Nichifu Terminal Industries CO.,LTD.	TMEV1.25Y-3	0.63 N•m
	Japan Solderless Terminal MFG CO.,LTD.	VD1.25-B3A	
Ring-type	Nichifu Terminal Industries CO.,LTD.	TMEV1.25-3	
	Japan Solderless Terminal MFG CO.,LTD.	V1.25-3	

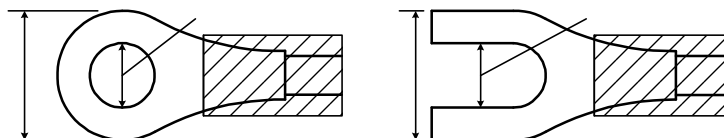

(Fig. 4-2)

# 5. Settings

## 5.1 Operation flowchart

### Outline of operation procedure

Set Input type, Alarm (type, value, etc.) and SV (desired value), following the procedures below. Setting item numbers (1) to (7) are indicated on the flowchart.

[Step 1 Operation before run]	Turn the load circuit power OFF, and turn the power supply to the BCD2 ON.
[Step 2 Setup mode]	Set Input type, Alarm type, etc. in Setup mode. <b>(1) Input type:</b> Select an input type. Refer to "Input type (character indication) and range" on page 7. <b>(2) A1 type:</b> Select an alarm type. Refer to "Alarm type" on page 7. [If an alarm type except for " - - - " is selected, items (3) to (5) will be indicated and they can be set if necessary.] <b>Note: If an alarm type is changed, the alarm value becomes 0 (0.0). Therefore it is necessary to set it again.</b> <b>(3) A1 action Energized/De-energized:</b> Select Alarm 1 action Energized or De-energized. <b>(4) A1 hysteresis:</b> Set A1 hysteresis. <b>(5) A1 action delay time:</b> Set A1 action delay time.
[Step 3 Main setting mode]	<b>(6) SV:</b> Set SV (desired value) in Main setting mode. <b>(7) A1 value:</b> Set action point of A1 output in Main setting mode.
[Step 4 Run]	Turn the load circuit power ON. Control action starts so as to keep the control target at the SV (Desired value).

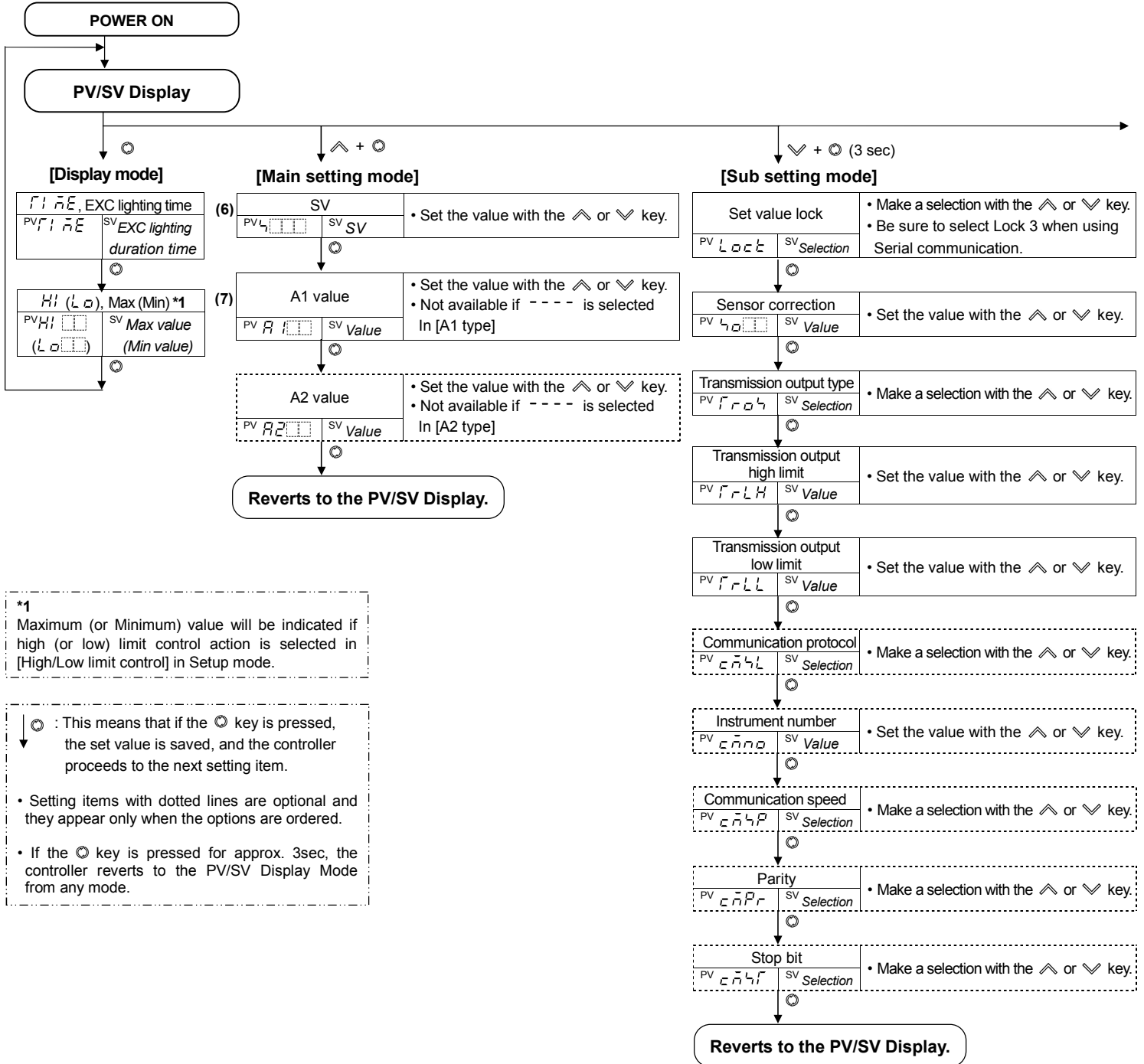

\*1 Maximum (or Minimum) value will be indicated if high (or low) limit control action is selected in [High/Low limit control] in Setup mode.

○ : This means that if the ○ key is pressed, the set value is saved, and the controller proceeds to the next setting item.

- Setting items with dotted lines are optional and they appear only when the options are ordered.
- If the ○ key is pressed for approx. 3sec, the controller reverts to the PV/SV Display Mode from any mode.

Input type (character indication) and range			
$t_{\square\square\square}C$ : K	-200 to 1370°C	$t_{\square\square\square}F$ : K	-320 to 2500°F
$t_{\square\square\square}C$ : C	-199.9 to 400.0°C	$t_{\square\square\square}F$ : F	-199.9 to 750.0°F
$t_{\square\square\square}C$ : J	-200 to 1000°C	$t_{\square\square\square}F$ : J	-320 to 1800°F
$r_{\square\square\square}C$ : R	0 to 1760°C	$r_{\square\square\square}F$ : R	0 to 3200°F
$t_{\square\square\square}C$ : S	0 to 1760°C	$t_{\square\square\square}F$ : S	0 to 3200°F
$b_{\square\square\square}C$ : B	0 to 1820°C	$b_{\square\square\square}F$ : B	0 to 3300°F
$E_{\square\square\square}C$ : E	-200 to 800°C	$E_{\square\square\square}F$ : E	-320 to 1500°F
$t_{\square\square\square}C$ : T	-199.9 to 400.0°C	$t_{\square\square\square}F$ : T	-199.9 to 750.0°F
$n_{\square\square\square}C$ : N	-200 to 1300°C	$n_{\square\square\square}F$ : N	-320 to 2300°F
$PL_{\square\square}C$ : PL-II	0 to 1390°C	$PL_{\square\square}F$ : PL-II	0 to 2500°F
$c_{\square\square\square}C$ : C(W/Re5-26)	0 to 2315°C	$c_{\square\square\square}F$ : C(W/Re5-26)	0 to 4200°F
$Pt_{\square\square}C$ : Pt100	-199.9 to 850.0°C	$Pt_{\square\square}F$ : Pt100	-199.9 to 999.9°F
$JPt_{\square\square}C$ : JPt100	-199.9 to 500.0°C	$JPt_{\square\square}F$ : JPt100	-199.9 to 900.0°F
$Pt_{\square\square}C$ : Pt100	-200 to 850°C	$Pt_{\square\square}F$ : Pt100	-300 to 1500°F
$JPt_{\square\square}C$ : JPt100	-200 to 500°C	$JPt_{\square\square}F$ : JPt100	-300 to 900°F
$420R$ : 4 to 20 mA DC	-1999 to 9999		
$020R$ : 0 to 20 mA DC	-1999 to 9999		
$018$ : 0 to 1 V DC	-1999 to 9999		
$058$ : 0 to 5 V DC	-1999 to 9999		
$158$ : 1 to 5 V DC	-1999 to 9999		
$0108$ : 1 to 10 V DC	-1999 to 9999		

Alarm type	
$H_{\square\square\square}$ (High limit alarm):	The alarm action is $\pm$ deviation setting from the SV. The alarm is activated if the PV (process variable) reaches the high limit set value.
$L_{\square\square\square}$ (Low limit alarm):	The alarm action is $\pm$ deviation setting from the SV. The alarm is activated if the PV (process variable) goes under the low limit set value.
$HL_{\square\square}$ (High/Low limits alarm):	Combines High limit and Low limit alarm actions. When PV (process variable) reaches high limit set value or goes under the low limit set value, the alarm is activated.
$\bar{L}d_{\square\square}$ (High/Low limit range alarm):	When PV (process variable) is between the high limit set value and low limit set value, the alarm is activated. If PV exceeds the high limit set value or goes under the low limit set value, the alarm output is turned off.
$R_{\square\square}$ (Process high alarm) $r_{\square\square}$ (Process low alarm)	Within the scale range of the controller, alarm action points can be set at random and if the PV (process variable) reaches the randomly set action point, the alarm is activated.
$H_{\square\square}\bar{L}$ (High limit alarm with standby) $L_{\square\square}\bar{L}$ (Low limit alarm with standby) $HL_{\square\square}\bar{L}$ (High/Low limits with standby)	When the power to the controller is turned on, even if the PV (process variable) enters the alarm action range, the alarm is not activated. Even if the PV enters the alarm action range due to SV change during running, the alarm is not activated, either. If the controller is allowed to keep running, once the input exceeds the alarm action point, the standby function will be released.

⏏ + ⏏ + ⏏ (3 sec)

[Setup mode]

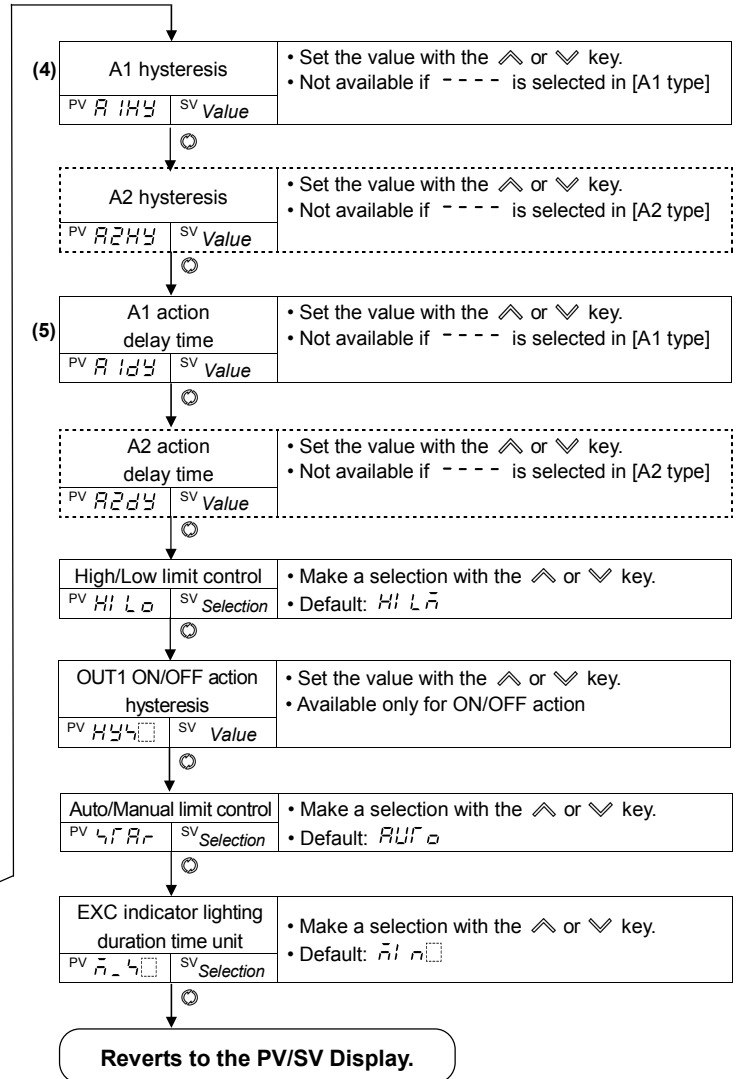
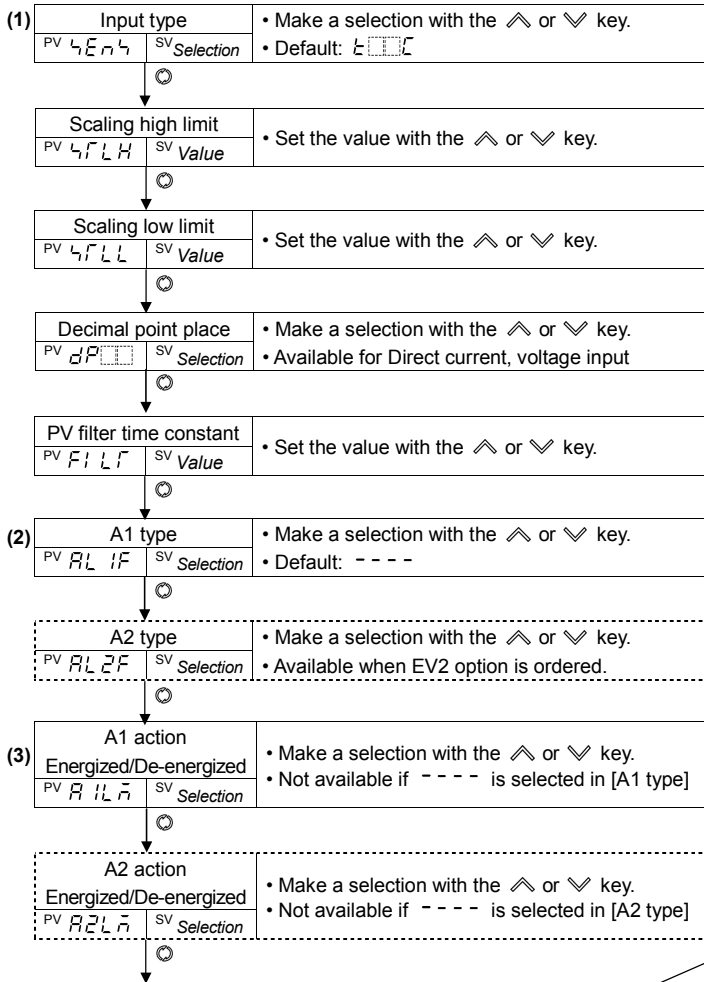



After the power is turned on, the sensor input characters and temperature unit are indicated in the PV Display, and the input range high limit value is indicated in the SV Display for approximately 3 seconds. See (Table 5-1).

(If any other value is set in [Scaling high limit], the value is indicated in the SV Display)

During this time, all outputs and the LED indicators are in OFF status.

Limit control will then start, indicating the PV (process variable) in the PV Display and SV (desired value) in the SV Display.

(Table 5-1)





Input type	°C		°F	
	PV Display	SV Display	PV Display	SV Display
K	6000	1370	600F	2500
	6000	4000	600F	7500
J	4000	1000	400F	1800
R	7000	1760	700F	3200
S	4000	1760	400F	3200
B	6000	1820	600F	3300
E	6000	800	600F	1500
T	7000	4000	700F	7500
N	7000	1300	700F	2300
PL-II	PL20	1390	PL2F	2500
C (W/Re5-26)	6000	2315	600F	4200
Pt100	PT00	8500	PT0F	9999
JPt100	PT00	850	PT0F	1500
	UPt00	5000	UPt0F	9000
	UPt00	500	UPt0F	900
4 to 20 mA DC	4200	Scaling high limit value		
0 to 20 mA DC	0200			
0 to 1 V DC	0010			
0 to 5 V DC	0050			
1 to 5 V DC	1050			
0 to 10 V DC	0100			

## 5.2 Display mode

Selects an item to be indicated in the PV and SV Displays.

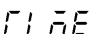
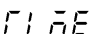
Every time the  key is pressed in the PV/SV Display Mode, the following indications are switched.

When power is turned ON, the PV Display indicates PV, and the SV Display indicates SV.

Display	Name, Function, Setting range
 EXC duration time	<b>FLnE, EXC indicator lighting duration time indication</b> <ul style="list-style-type: none"> <li>The PV Display indicates , and the SV Display indicates “EXC indicator lighting duration time”.</li> <li>Measurement range: 0:00 to 99:59 The time unit can be selected in [EXC indicator lighting duration time unit] in Setup mode.</li> <li>Reverts to the default value (0:00 Hour:Minute/Minute:Second) if the <b>RST</b> key is pressed or if the external reset input terminals 9 and 12 are shorted.</li> </ul>
  Max (Min) value	<b>Hi (Lo), Maximum (Minimum) value indication</b> <ul style="list-style-type: none"> <li>While the EXC indicator lights, the PV Display indicates  or , and the SV Display indicates the maximum or minimum value. If High limit control action (or Low limit control action) is selected in [High/Low limit control] in Setup mode, the maximum value (or minimum value) is indicated.</li> <li>Reverts to the current PV (input value) if the <b>RST</b> key is pressed or if the external reset input terminals 9 and 12 are shorted.</li> </ul>

### 5.3 Main setting mode

Sets SV, A1 and A2 value.

To enter Main setting mode, press the  $\wedge$  and  $\odot$  keys (in that order) together in PV/SV Display Mode.

Use the  $\wedge$  or  $\vee$  key for settings (or selections).

To register the set data, use the  $\odot$  key..

Character	Name, Function, Setting range	Default value
SV	<b>SV</b> • Sets SV (desired value). • Setting range: Scaling low limit to Scaling high limit	0°C
A1	<b>A1 value</b> • Sets the action point of Alarm 1 (A1) output. • Not available if No alarm is selected in [A1 type]. • Setting range: Refer to (Table 5.3-1).	0°C
A2	<b>A2 value</b> • Sets the action point of Alarm 2 (A2) output. • Not available if No alarm is selected in [A2 type], or the EV2 option is not ordered. • Setting range: Refer to (Table 5.3-1).	0°C

(Table 5.3-1)

Alarm type	Setting range	
High limit alarm	– (Input span) to input span°C(°F)	*1
Low limit alarm	– (Input span) to input span°C(°F)	*1
High/Low limits alarm	0 to input span°C(°F)	*1
High/Low limit range alarm	0 to input span°C(°F)	*1
Process high alarm	Input range low limit value to input range high limit value	*2
Process low alarm	Input range low limit value to input range high limit value	*2
High limit alarm with standby	– (Input span) to input span°C(°F)	*1
Low limit alarm with standby	– (Input span) to input span°C(°F)	*1
High/Low limits alarm with standby	0 to input span°C(°F)	*1

• When input has a decimal point, the negative low limit value is –199.9, and the positive high limit value is 999.9.

• All alarm actions except process alarm are  $\pm$  deviation setting from the SV (desired value).

\*1: For DC input, the input span is the same as the scaling span.

\*2: For DC input, input range low (or high) limit value is the same as scaling low (or high) limit value.

### 5.4 Sub setting mode

Sets Set value lock, Sensor correction, Communication parameters (when C5 option is ordered), etc.

To enter Sub setting mode, press and hold the  $\vee$  and  $\odot$  keys (in that order) together for 3 seconds in PV/SV Display Mode.

Use the  $\wedge$  or  $\vee$  key for settings (or selections).

To register the set data, use the  $\odot$  key.

Character	Name, Function, Setting range	Default value
Lock	<b>Set value lock</b> • Locks the set values to prevent setting errors. The setting item to be locked depends on the selection. • Selection range: ---- (Unlock): All set values can be changed. Loc 1 (Lock 1): None of the set values can be changed. Loc 2 (Lock 2): Only SV (desired value) can be changed. Loc 3 (Lock 3): All set values can be changed. However, do not change any setting item in the Setup mode. Changed values revert to their previous value after power is turned off because they are not saved in the non-volatile memory.	Unlock
SV	<b>Sensor correction</b> • Sets the correction value for the sensor. (Effective within the input rating value regardless of the sensor correction value) PV= Current actual temperature + Sensor correction value • Setting range: –100.0 to 100.0°C (°F) DC input: -1000 to 1000	0.0°C

Character	Name, Function, Setting range	Default value
<i>FrOH</i>	<b>Transmission output type</b> • Selects PV or SV transmission. • Selection item: <i>PV</i> <input type="checkbox"/> : PV transmission <i>SV</i> <input type="checkbox"/> : SV transmission	PV transmission
<i>FrLH</i>	<b>Transmission output high limit</b> • Sets Transmission output high limit value. • Setting range: Transmission output low limit value to Input range high limit value	1370°C
<i>FrLL</i>	<b>Transmission output low limit</b> • Sets Transmission output low limit value. • Setting range: Input range low limit value to Transmission output high limit value.	-200°C
<i>CnL</i>	<b>Communication protocol</b> • Selects the communication protocol. • Available only when the C5 option is applied. • Selection: <i>Shinko</i> <input type="checkbox"/> : Shinko protocol <i>Modbus ASCII</i> <input type="checkbox"/> : Modbus ASCII mode <i>Modbus RTU</i> <input type="checkbox"/> : Modbus RTU mode	Shinko protocol
<i>CnNo</i>	<b>Instrument number</b> • Sets the instrument number individually to each instrument when communicating by connecting plural instruments in serial communication. • Available only when the C5 option is ordered. • Setting range: 0 to 95	0
<i>CnSP</i>	<b>Communication speed</b> • Selects a communication speed equal to that of the host computer. • Available only when the C5 option is ordered. • Selection: <i>24</i> <input type="checkbox"/> : 2400 bps <i>48</i> <input type="checkbox"/> : 4800 bps <i>96</i> <input type="checkbox"/> : 9600 bps <i>192</i> <input type="checkbox"/> : 19200 bps	9600 bps
<i>CnPr</i>	<b>Parity</b> • Selects the parity. • Not available if the C5 option is not ordered or if Shinko protocol is selected in [Communication protocol]. • Selection: <i>None</i> <input type="checkbox"/> : No parity <i>Even</i> <input type="checkbox"/> : Even parity <i>Odd</i> <input type="checkbox"/> : Odd parity	Even parity
<i>CnSt</i>	<b>Stop bit</b> • Selects the stop bit. • Not available if the C5 option is not ordered or if Shinko protocol is selected in [Communication protocol]. • Selection: <i>1</i> <input type="checkbox"/> : 1 bit <i>2</i> <input type="checkbox"/> : 2 bits	1 bit

## 5.5 Setup mode

Sets an input type, A1, A2 type, High/Low limit control, etc.

To enter Setup mode, press and hold the  $\wedge$ ,  $\vee$  and  $\odot$  keys (in that order) together for 3 seconds in PV/SV Display Mode.

Use the  $\wedge$  or  $\vee$  key for settings (or selections).

To register the set data, use the  $\odot$  key.

Character	Name, Function, Setting range	Default value																																																												
4En4	<p><b>Input type</b></p> <ul style="list-style-type: none"> <li>The input type can be selected from thermocouple (10 types), RTD (2 types), Direct current (2 types) and DC voltage (4 types), and the unit °C/°F can be selected as well.</li> <li>When changing the input from DC voltage to other inputs, remove the sensor connected to this controller first, then change the input. If the input is changed with the sensor connected, the input circuit may break.</li> </ul> <p>• Selection range:</p> <table border="0"> <tr> <td>400C: K</td> <td>-200 to 1370°C</td> <td>400F: K</td> <td>-320 to 2500°F</td> </tr> <tr> <td>400E: K</td> <td>-199.9 to 400.0°C</td> <td>400F: K</td> <td>-199.9 to 750.0°F</td> </tr> <tr> <td>400J: J</td> <td>-200 to 1000°C</td> <td>400F: J</td> <td>-320 to 1800°F</td> </tr> <tr> <td>400R: R</td> <td>0 to 1760°C</td> <td>400F: R</td> <td>0 to 3200°F</td> </tr> <tr> <td>400S: S</td> <td>0 to 1760°C</td> <td>400F: S</td> <td>0 to 3200°F</td> </tr> <tr> <td>400B: B</td> <td>0 to 1820°C</td> <td>400F: B</td> <td>0 to 3300°F</td> </tr> <tr> <td>400E: E</td> <td>-200 to 800°C</td> <td>400F: E</td> <td>-320 to 1500°F</td> </tr> <tr> <td>400T: T</td> <td>-199.9 to 400.0°C</td> <td>400F: T</td> <td>-199.9 to 750.0°F</td> </tr> <tr> <td>400N: N</td> <td>-200 to 1300°C</td> <td>400F: N</td> <td>-320 to 2300°F</td> </tr> <tr> <td>420C: PL-II</td> <td>0 to 1390°C</td> <td>420F: PL-II</td> <td>0 to 2500°F</td> </tr> <tr> <td>400C: C(W/Re5-26)</td> <td>0 to 2315°C</td> <td>400F: C(W/Re5-26)</td> <td>0 to 4200°F</td> </tr> <tr> <td>400C: Pt100</td> <td>-199.9 to 850.0°C</td> <td>400F: Pt100</td> <td>-199.9 to 999.9°F</td> </tr> <tr> <td>400C: JPt100</td> <td>-199.9 to 500.0°C</td> <td>400F: JPt100</td> <td>-199.9 to 900.0°F</td> </tr> <tr> <td>400C: Pt100</td> <td>-200 to 850°C</td> <td>400F: Pt100</td> <td>-300 to 1500°F</td> </tr> <tr> <td>400C: JPt100</td> <td>-200 to 500°C</td> <td>400F: JPt100</td> <td>-300 to 900°F</td> </tr> </table> <p>420A: 4 to 20 mA DC -1999 to 9999            020A: 0 to 20 mA DC -1999 to 9999            001V: 0 to 1 V DC -1999 to 9999            005V: 0 to 5 V DC -1999 to 9999            105V: 1 to 5 V DC -1999 to 9999            010V: 0 to 10 V DC -1999 to 9999</p>	400C: K	-200 to 1370°C	400F: K	-320 to 2500°F	400E: K	-199.9 to 400.0°C	400F: K	-199.9 to 750.0°F	400J: J	-200 to 1000°C	400F: J	-320 to 1800°F	400R: R	0 to 1760°C	400F: R	0 to 3200°F	400S: S	0 to 1760°C	400F: S	0 to 3200°F	400B: B	0 to 1820°C	400F: B	0 to 3300°F	400E: E	-200 to 800°C	400F: E	-320 to 1500°F	400T: T	-199.9 to 400.0°C	400F: T	-199.9 to 750.0°F	400N: N	-200 to 1300°C	400F: N	-320 to 2300°F	420C: PL-II	0 to 1390°C	420F: PL-II	0 to 2500°F	400C: C(W/Re5-26)	0 to 2315°C	400F: C(W/Re5-26)	0 to 4200°F	400C: Pt100	-199.9 to 850.0°C	400F: Pt100	-199.9 to 999.9°F	400C: JPt100	-199.9 to 500.0°C	400F: JPt100	-199.9 to 900.0°F	400C: Pt100	-200 to 850°C	400F: Pt100	-300 to 1500°F	400C: JPt100	-200 to 500°C	400F: JPt100	-300 to 900°F	K (-200 to 1370°C)
400C: K	-200 to 1370°C	400F: K	-320 to 2500°F																																																											
400E: K	-199.9 to 400.0°C	400F: K	-199.9 to 750.0°F																																																											
400J: J	-200 to 1000°C	400F: J	-320 to 1800°F																																																											
400R: R	0 to 1760°C	400F: R	0 to 3200°F																																																											
400S: S	0 to 1760°C	400F: S	0 to 3200°F																																																											
400B: B	0 to 1820°C	400F: B	0 to 3300°F																																																											
400E: E	-200 to 800°C	400F: E	-320 to 1500°F																																																											
400T: T	-199.9 to 400.0°C	400F: T	-199.9 to 750.0°F																																																											
400N: N	-200 to 1300°C	400F: N	-320 to 2300°F																																																											
420C: PL-II	0 to 1390°C	420F: PL-II	0 to 2500°F																																																											
400C: C(W/Re5-26)	0 to 2315°C	400F: C(W/Re5-26)	0 to 4200°F																																																											
400C: Pt100	-199.9 to 850.0°C	400F: Pt100	-199.9 to 999.9°F																																																											
400C: JPt100	-199.9 to 500.0°C	400F: JPt100	-199.9 to 900.0°F																																																											
400C: Pt100	-200 to 850°C	400F: Pt100	-300 to 1500°F																																																											
400C: JPt100	-200 to 500°C	400F: JPt100	-300 to 900°F																																																											
4FLH	<p><b>Scaling high limit</b></p> <ul style="list-style-type: none"> <li>Sets scaling high limit value.</li> <li>Setting range: Scaling low limit value to input range high limit value</li> </ul>	1370°C																																																												
4FL L	<p><b>Scaling low limit</b></p> <ul style="list-style-type: none"> <li>Sets scaling low limit value.</li> <li>Setting range: Input range low limit value to scaling high limit value</li> </ul>	-200°C																																																												
dP00	<p><b>Decimal point place</b></p> <ul style="list-style-type: none"> <li>Selects decimal point place.</li> <li>Available only for DC input</li> <li>Selection range:               <table border="0"> <tr> <td>0000</td> <td>No decimal point</td> </tr> <tr> <td>0000</td> <td>1 digit after decimal point</td> </tr> <tr> <td>0000</td> <td>2 digits after decimal point</td> </tr> <tr> <td>0000</td> <td>3 digits after decimal point</td> </tr> </table> </li> </ul>	0000	No decimal point	0000	1 digit after decimal point	0000	2 digits after decimal point	0000	3 digits after decimal point	No decimal point																																																				
0000	No decimal point																																																													
0000	1 digit after decimal point																																																													
0000	2 digits after decimal point																																																													
0000	3 digits after decimal point																																																													
FILF	<p><b>PV filter time constant</b></p> <ul style="list-style-type: none"> <li>Sets PV filter time constant. (If the value is set too large, it affects control result due to the delay of response)</li> <li>Setting range: 0.0 to 10.0 seconds</li> </ul>	0.0 sec.																																																												

Character	Name, Function, Setting range	Default value
<i>ALIF</i>	<b>A1 type</b> <ul style="list-style-type: none"> <li>• Selects an action type for A1.</li> <li>• Selection range: <ul style="list-style-type: none"> <li>---- : No alarm action</li> <li>H□□□ : High limit alarm</li> <li>L□□□ : Low limit alarm</li> <li>HL□□ : High/Low limits alarm</li> <li>u l d□ : High/Low limit range alarm</li> <li>RA□□ : Process high alarm</li> <li>r RA□□ : Process low alarm</li> <li>H□□□ : High limit alarm with standby</li> <li>L□□□ : Low limit alarm with standby</li> <li>HL□□ : High/Low limits alarm with standby</li> </ul> </li> </ul>	No alarm action
<i>AL2F</i>	<b>A2 type</b> <ul style="list-style-type: none"> <li>• Selects an action type for A2.</li> <li>• Available only when EV2 option is ordered</li> <li>• Selection range and default value are the same as those of A1 type.</li> </ul>	No alarm action
<i>A1Lā</i>	<b>A1 action Energized/De-energized</b> <ul style="list-style-type: none"> <li>• Selects Energized/De-energized for A1.</li> <li>• Not available if No alarm action is selected in [A1 type]</li> <li>• Selection range: <ul style="list-style-type: none"> <li>noāL : Energized</li> <li>rEāL : De-energized</li> </ul> </li> </ul>	Energized
<i>A2Lā</i>	<b>A2 action Energized/De-energized</b> <ul style="list-style-type: none"> <li>• Selects Energized/De-energized for A2.</li> <li>• Not available if EV2 option is not ordered or if No alarm action is selected in [A2 type].</li> <li>• Selection range and default value are the same as those of A1 action Energized/De-energized.</li> </ul>	Energized
<i>A1HY</i>	<b>A1 hysteresis</b> <ul style="list-style-type: none"> <li>• Sets A1 hysteresis.</li> <li>• Not available if No alarm action is selected in [A1 type]</li> <li>• Setting range: 0.1 to 100.0°C (°F), or 1 to 1000</li> </ul>	1.0°C
<i>A2HY</i>	<b>A2 hysteresis</b> <ul style="list-style-type: none"> <li>• Sets A2 hysteresis.</li> <li>• Not available if EV2 option is not ordered or if No alarm action is selected in [A2 type].</li> <li>• Setting range: 0.1 to 100.0°C (°F), or 1 to 1000</li> </ul>	1.0°C
<i>A1dY</i>	<b>A1 action delay time</b> <ul style="list-style-type: none"> <li>• Sets A1 action delay time.</li> <li>When setting time has elapsed after the input enters the alarm output range, the alarm is activated.</li> <li>• Not available if No alarm action is selected in [A1 type]</li> <li>• Setting range: 0 to 9999 seconds</li> </ul>	0 sec.
<i>A2dY</i>	<b>A2 action delay time</b> <ul style="list-style-type: none"> <li>• Sets A2 action delay time.</li> <li>When setting time has elapsed after the input enters the alarm output range, the alarm is activated.</li> <li>• Not available if EV2 option is not ordered or if No alarm action is selected in [A2 type].</li> <li>• Setting range: 0 to 9999 seconds</li> </ul>	0 sec.
<i>HiLo</i>	<b>High/Low limit control</b> <ul style="list-style-type: none"> <li>• Selects either High limit or Low limit control action.</li> <li>(Refer to Sections 7.1, 7.2)</li> <li>• Selection item: <ul style="list-style-type: none"> <li>HiLā : High limit control</li> <li>LoLā : Low limit control</li> </ul> </li> </ul>	High limit control
<i>HY4□</i>	<b>OUT1 ON/OFF action hysteresis</b> <ul style="list-style-type: none"> <li>• Sets OUT1 (Limit control output) ON/OFF action hysteresis.</li> <li>• Setting range: 0.1 to 100.0°C(°F), or 1 to 1000</li> </ul>	1.0°C

Character	Name, Function, Setting range	Default value
4FAR	<b>Auto/Manual limit control</b> <ul style="list-style-type: none"> <li>• Selects either auto or manual limit control action. (Refer to Section 7.3)</li> <li>• Selection item:            AUTO: Auto limit control            MANU: Manual limit control</li> </ul>	Auto limit control
n4	<b>EXC indicator lighting duration time unit</b> <ul style="list-style-type: none"> <li>• Selects unit of "EXC indicator lighting duration time".</li> <li>• Selection range:            H:M: Hour:Minute            M:S: Minute:Second</li> </ul>	Hour:Minute

### Sensor correction function

This corrects the input value from the sensor. When a sensor cannot be set at the exact location where control is desired, the sensor-measured temperature may deviate from the temperature in the controlled location. When using multiple controllers, sometimes the measured temperatures do not concur due to differences in sensor accuracy or dispersion of load capacities. In such a case, the control can be set at the desired temperature by adjusting the input value of sensors.

### Alarm Energized/De-energized

When A1/A2 Energized is selected, the A1/A2 output (terminals 17-18, or 19-20) is conducted (ON) while the A1/A2 indicator is lit.

The A1/A2 output is not conducted (OFF) while the A1/A2 indicator is not lit.

When A1/A2 De-energized is selected, the A1/A2 output (terminals 17-18, or 19-20) is not conducted (OFF) while the A1/A2 indicator is lit.

The A1/A2 output is conducted (ON) while the A1/A2 indicator is not lit.

### High limit alarm (when Energized is set)      High limit alarm (when De-energized is set)

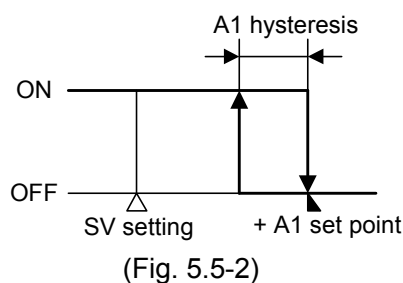
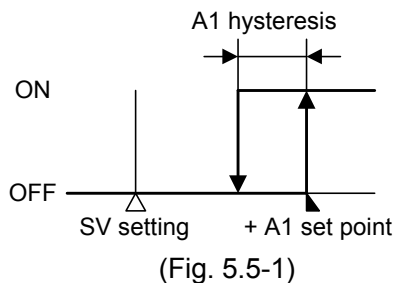

A1: Alarm 1  
For Alarm 2(A2), read A2 for A1

## 6. Operation

After the unit is mounted to the control panel and wiring is completed, operate the unit following the procedure below.

### (1) Turn the power supply to the BCD2 ON.

Turn the power supply to the BCD2 ON.

- For approx. 3 seconds after the power is switched ON, the input characters and the temperature unit are indicated in the PV Display and input range high limit value is indicated in the SV Display. See (Table 5-1). (If any other value has been set in [Scaling high limit], the value is indicated in the SV Display.)

During this time, all outputs and LED indicators are in OFF status.

- After that, control starts, indicating PV (process variable) in the PV Display, and SV (desired value) in the SV Display.

### (2) Input each set value.

Input each set value, referring to "5. Settings".

### (3) Turn the load circuit power ON.

Limit control action starts.

# 7. Action explanation

## 7.1 High limit control action (Fig. 7.1-1)

Auto limit control will be used for purposes of explanation of the High limit control action. (Refer to Section 7.3)

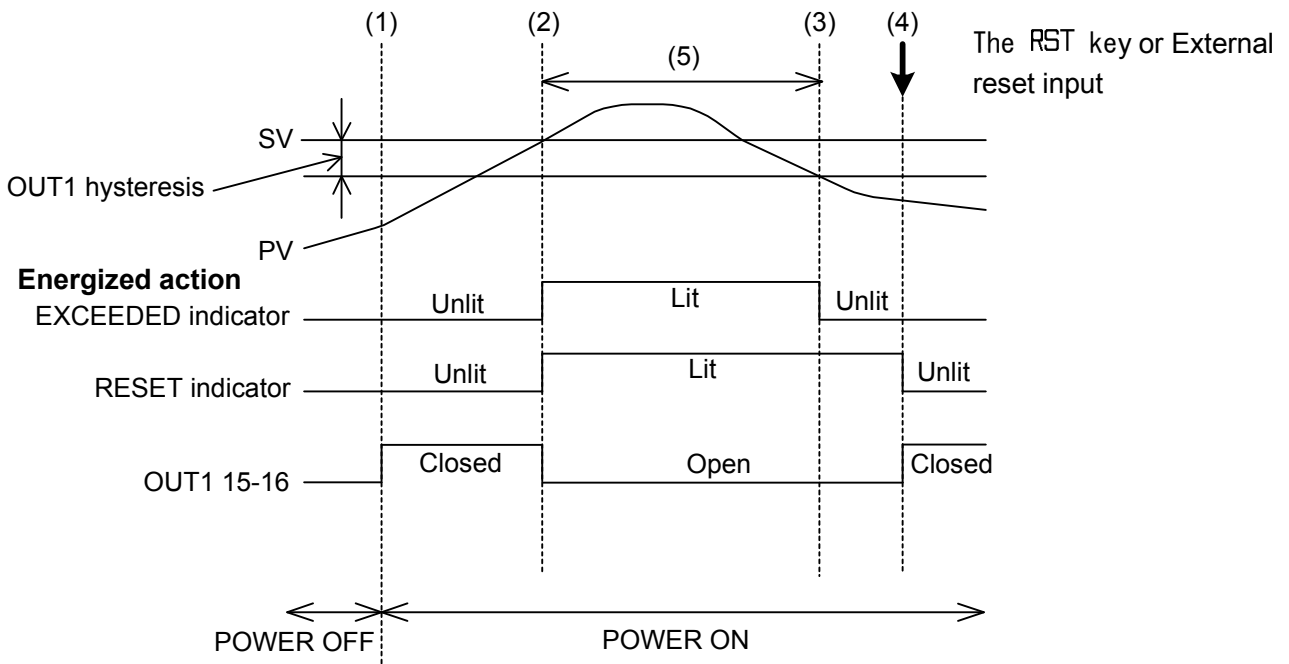

(Fig. 7.1-1)

- (1) Limit control action will initiate after power supply to the controller is turned on.
- (2) If PV exceeds SV, the EXCEEDED and RESET indicators light, and OUT1 (Limit control output terminals 15 and 16) is turned OFF.
- (3) If PV drops below [SV-OUT1 hysteresis], the EXCEEDED indicator goes off. At this time, the RESET indicator is lit, and OUT1 (Limit control output terminals 15 and 16) is in OFF status.
- (4) If the RST key is pressed, or if external reset input terminals 9 and 12 are shorted, the RESET indicator goes off, OUT1 (Limit control output terminals 15 and 16) is turned ON, and limit control action initiates again.
- (5) While the EXCEEDED indicator is lit, even if the RST key is pressed or even if external reset input terminals 9 and 12 are shorted, limit control action does not initiate.

## 7.2 Low limit control action (Fig. 7.2-1)

Auto limit control will be used for purposes of explanation of the Low limit control action. (Refer to Section 7.3)

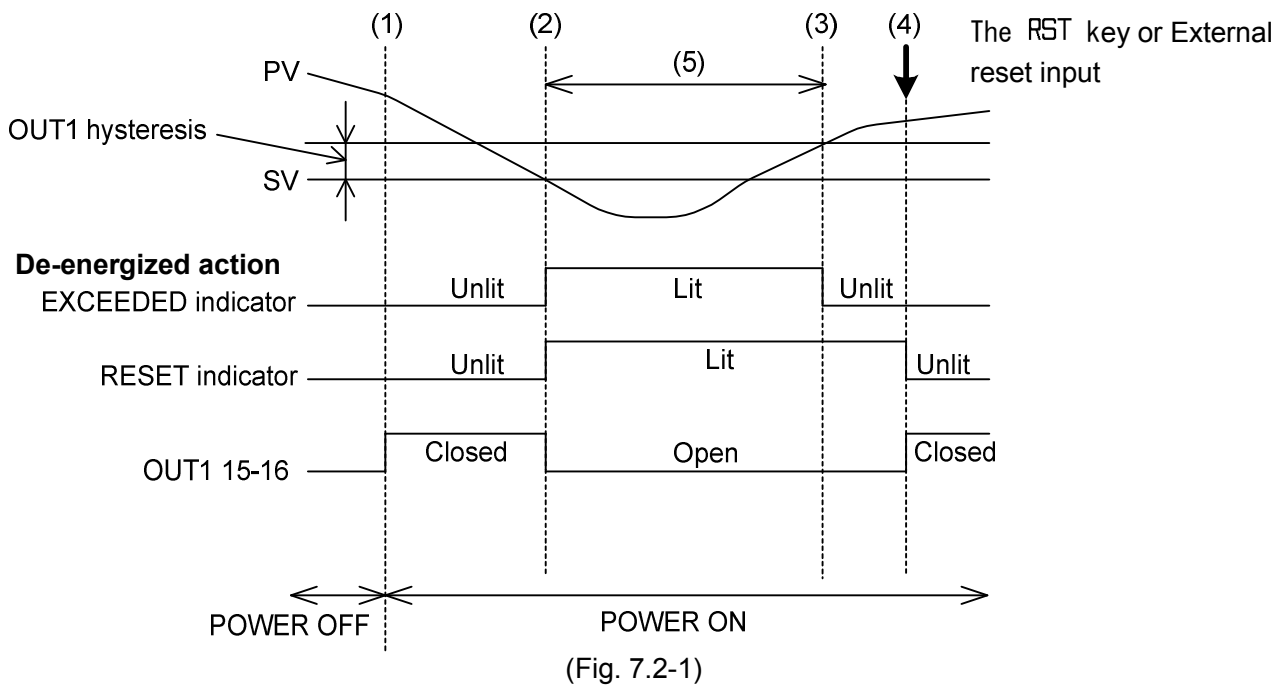

- (1) Limit control action will initiate after power supply to the controller is turned on.
- (2) If PV drops below SV, the EXCEEDED and RESET indicators light, and OUT1 (Limit control output terminals 15 and 16) is turned OFF.
- (3) If PV exceeds [SV+OUT1 hysteresis], the EXCEEDED indicator goes off. At this time, the RESET indicator is lit, and OUT1 (Limit control output terminals 15 and 16) is in OFF status.
- (4) If the RST key is pressed, or if external reset input terminals 9 and 12 are shorted, the RESET indicator goes off, OUT1 (Limit control output terminals 15 and 16) is turned ON, and limit control action initiates again.
- (5) While the EXCEEDED indicator is lit, even if the RST key is pressed or even if external reset input terminals 9 and 12 are shorted, limit control action does not initiate.

## 7.3 Auto/Manual limit control

### Auto limit control

When the power supply is turned on, or after the power is restored, the AUTO indicator lights, and limit control starts automatically even if the RST key is not pressed, or even if external reset input is not shorted.

For High limit control, when PV exceeds SV-Hysteresis, the limit control action does not initiate.

For Low limit control, when PV drops below SV+Hysteresis, the limit control action does not initiate.

Limit control action does not initiate while the EXCEEDED indicator is lit.

### Manual limit control

In the following cases, the RESET indicator lights, and it is necessary to reset the unit manually. (Press the RST key, or short the external reset input terminals.)

- When power is turned on
- When power is restored
- For High limit control, when PV drops below the SV-Hysteresis after PV exceeded SV.  
For Low limit control, when PV exceeds the SV+Hysteresis after PV dropped below SV.  
However, the limit control action does not initiate as follows (Same as Auto limit control).  
For High limit control, when PV exceeds SV-Hysteresis, the limit control action does not initiate.  
For Low limit control, when PV drops below SV+Hysteresis, the limit control action does not initiate.  
Limit control action does not initiate while the EXCEEDED indicator is lit.



## 7.4 A1, A2 action

	High limit alarm	Low limit alarm	High/Low limits alarm
A1 action			
A1 output			
	High/Low limit range alarm	Process high alarm	Process low alarm
A1 action			
A1 output			
	High limit alarm with standby	Low limit alarm with standby	High/Low limits alarm with standby
A1 action			
A1 output			

- : A1 output terminals 17, 18 (A2 output terminals 19, 20): ON (closed).
- : A1 output terminals 17, 18 (A2 output terminals 19, 20): ON (closed) or OFF (open)
- : A1 output terminals 17, 18 (A2 output terminals 19, 20): OFF (open)
- : Alarm output is in standby.

- For A2, read A2 for A1.
- A1 indicator lights when A1 output terminals 17 and 18 are ON, and goes off when their output terminals 17 and 18 are OFF.
- A2 indicator lights when A2 output terminals 19 and 20 are ON, and goes off when their output terminals 19 and 20 are OFF.

# 8. Specifications

## 8.1 Standard specifications

**Mounting:** Flush

**Setting:** Input system using membrane sheet key

**Display** PV Display: Red LED 4 digits, character size 24 x 11 mm (H x W)  
SV Display: Green LED 4 digits, character size 14 x 7 mm (H x W)

**Accuracy (Setting and Indication):**

Thermocouple: Within  $\pm 0.2\%$  of each input span  $\pm 1$  digit, or within  $\pm 2^{\circ}\text{C}$  ( $4^{\circ}\text{F}$ ), whichever is greater  
However R, S inputs, 0 to  $200^{\circ}\text{C}$  ( $32$  to  $392^{\circ}\text{F}$ ): Within  $\pm 6^{\circ}\text{C}$  ( $12^{\circ}\text{F}$ )  
B input, 0 to  $300^{\circ}\text{C}$  ( $0$  to  $572^{\circ}\text{F}$ ): Accuracy is not guaranteed.  
K, J, E, T, N inputs, less than  $0^{\circ}\text{C}$  ( $32^{\circ}\text{F}$ ): Within  $\pm 0.4\%$  of input span  $\pm 1$  digit  
RTD: Within  $\pm 0.1\%$  of each input span  $\pm 1$  digit, or within  $\pm 1^{\circ}\text{C}$  ( $2^{\circ}\text{F}$ ), whichever is greater  
Direct current: Within  $\pm 0.2\%$  of each input span  $\pm 1$  digit  
DC voltage: Within  $\pm 0.2\%$  of each input span  $\pm 1$  digit

**Input sampling period:** 0.25 seconds

**Input** Thermocouple: K, J, R, S, B, E, T, N, PL-II, C(W/Re5-26), External resistance,  $100\ \Omega$  or less (However, B input: External resistance,  $40\ \Omega$  or less)  
RTD: Pt100, JPt100, 3-wire type  
Allowable input lead wire resistance ( $10\ \Omega$  or less per wire)  
Direct current: 0 to 20 mA DC, 4 to 20 mA DC  
Input impedance:  $50\ \Omega$   
Allowable input current: 50 mA or less  
Built-in shunt resistor ( $50\ \Omega$ )  
DC voltage: 0 to 1 V DC:  
Input impedance:  $1\ \text{M}\Omega$  or more  
Allowable input voltage: 5 V or less  
Allowable signal source resistance:  $2\ \text{k}\Omega$  or less  
0 to 5 V DC, 1 to 5 V DC, 0 to 10 V DC:  
Input impedance:  $100\ \text{k}\Omega$  or more  
Allowable input voltage: 15 V or less  
Allowable signal source resistance:  $100\ \Omega$  or less

**OUT1 (Limit control output)**

Relay contact 1a, Control capacity: 3 A 250 V AC (resistive load)  
1 A 250 V AC (inductive load  $\cos\phi=0.4$ )  
Electrical life: 100,000 cycles  
Minimum applicable load: 10 mA 5 V DC

**A1 output**

Action: ON/OFF action  
Hysteresis:  $0.1$  to  $100.0^{\circ}\text{C}$  ( $^{\circ}\text{F}$ ), 1 to 1000 (DC input) (Default:  $1.0^{\circ}\text{C}$ )  
Output: Relay contact 1a  
Control capacity: 3 A 250 V AC (resistive load)  
1 A 250 V AC (inductive load  $\cos\phi=0.4$ )  
Electrical life: 100,000 cycles  
Minimum applicable load: 10 mA 5 V DC

**Control action**

High limit control action, Low limit control action  
OUT1 (Limit control output) hysteresis:  $0.1$  to  $100.0^{\circ}\text{C}$  ( $^{\circ}\text{F}$ ), or 1 to 1000 (DC input)

**External reset input function**

By connecting External reset input terminals 9 and 12 (while the RESET indicator is lit), the RESET indicator goes off, OUT1 (Limit control output terminals 15 and 16) is turned ON, and limit control action initiates.

However, while the EXCEEDED indicator is lit, limit control action does not initiate even though External reset input terminals 9 and 12 are shorted.

- Contact 9-12 Open: Reset OFF
- Contact 9-12 Closed: Reset ON
- Circuit current when closed: 16 mA

**Circuit insulation configuration**

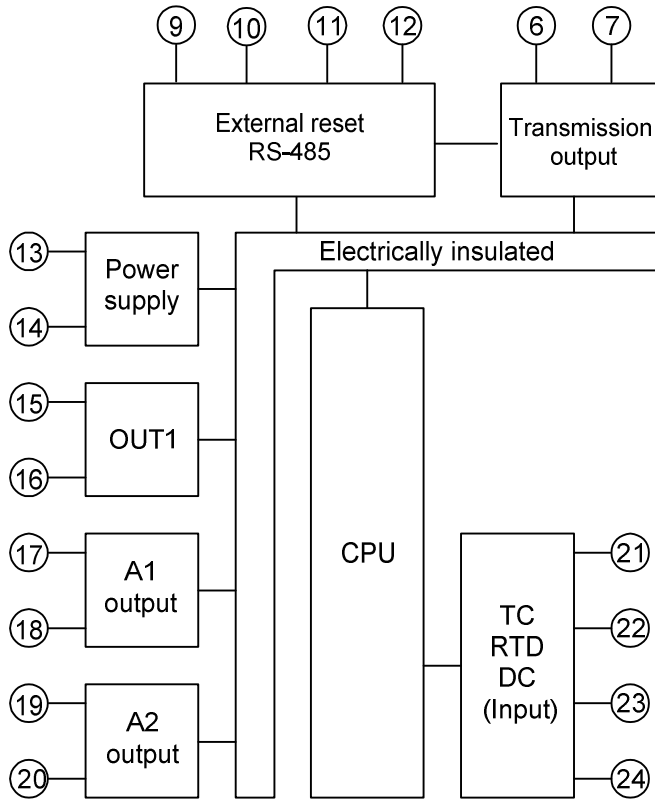

**Insulation resistance:** 10 MΩ or more, at 500 V DC

**Dielectric strength:** Between input terminal and power terminal: 1.5 kV AC for 1 minute  
 Between output terminal and power terminal: 1.5 kV AC for 1 minute

**Supply voltage:** 100 to 240 V AC 50/60 Hz, 24 V AC/DC 50/60 Hz

**Allowable voltage fluctuation:** 100 to 240 V AC: 85 to 264 V AC  
 24 V AC/DC: 20 to 28 V AC/DC

**Power consumption:**

- 100 to 240 V AC: Approx. 8 VA max.  
 (When the maximum number of options are ordered: Approx. 11 VA max.)
- 24 V AC: Approx. 5 VA max. (When the maximum number of options are ordered: Approx. 8 VA max.)
- 24 V DC: Approx. 5 W max. (When the maximum number of options are ordered: Approx. 8 W max.)

**Ambient temperature:** -10 to 55°C (14 to 131°F) (Non-condensing, No icing)

**Ambient humidity:** 35 to 85 %RH (Non-condensing)

**Weight:** Approx. 220 g

**External dimensions:** 96 x 96 x 68 mm (W x H x D) (Depth of control panel interior: 60 mm)

**Material:** Flame-resistant resin (Case)

**Color:** Black (Case)

**Attached functions:**

**[Set value lock]**

**[Sensor correction]**

**[Auto/Manual limit control]**

**[Input error indication]:**

**Thermocouple, RTD input:**

If measured value exceeds Indication range high limit value, the PV Display flashes “- - - -”.

If measured value drops below Indication range low limit value, the PV Display flashes “\_ \_ \_ \_”.

If measured value goes out of the Control range, OUT1 (Limit control output) is turned OFF.

Input	Input range	Indication range	Control range
K, T	-199.9 to 400.0°C	-199.9 to 450.0°C	-205.0 to 450.0°C
	-199.9 to 750.0°F	-199.9 to 850.0°F	-209.0 to 850.0°F
Pt100	-199.9 to 850.0°C	-199.9 to 900.0°C	-210.0 to 900.0°C
	-200 to 850°C	-210 to 900°C	-210 to 900°C
	-199.9 to 999.9°F	-199.9 to 999.9°F	-211.0 to 1099.9°F
	-300 to 1500°F	-318 to 1600°F	-318 to 1600°F
JPt100	-199.9 to 500.0°C	-199.9 to 550.0°C	-206.0 to 550.0°C
	-200 to 500°C	-207 to 550°C	-207 to 550°C
	-199.9 to 900.0°F	-199.9 to 999.9°F	-211.0 to 999.9°F
	-300 to 900°F	-312 to 1000°F	-312 to 1000°F

Indication range and Control range for thermocouple inputs other than the above:

Input range low limit value -50°C (100°F) to Input range high limit value +50°C (100°F)

Contents and Indication	Output status
	(15)-(16)
Measured value has exceeded Indication range high limit value. “- - - -” flashes.	Open
Measured value has dropped below Indication range low limit value. “_ _ _ _” flashes.	Open

**DC input:**

Indication range: [Scaling low limit value–Scaling span x 1%] to [Scaling high limit value +Scaling span x 10%]

However, “- - - -” or “\_ \_ \_ \_” flashes when a range of -1999 to 9999 is exceeded.

Control range: [Scaling low limit value–Scaling span x 1%] to [Scaling high limit value +Scaling span x 10%]

**DC input disconnection:**

When DC input is disconnected, the PV Display flashes “\_ \_ \_ \_” for 4 to 20 mA

DC and 1 to 5 V DC inputs, and “- - - -” for 0 to 1 V DC input. For 0 to 20 mA DC, 0 to 5 V DC and 0 to 10 V DC inputs, the PV Display indicates the value corresponding with 0 mA or 0 V input.

**[Burnout]**

When the thermocouple or RTD input is burnt out, OUT1 (Limit control output) is turned off, the PV becomes its maximum value and the PV Display flashes “- - - -”.

**[Self-diagnosis]**

The CPU is monitored by a watchdog timer, and if an abnormal status is found on the CPU, the controller is switched to warm-up status.

**[Automatic cold junction temperature compensation] (Only thermocouple input type)**

This detects the temperature at the connecting terminal between the thermocouple and the instrument, and always maintains at the same status as if the reference junction location temperature was at 0°C (32°F).

**[Power failure countermeasure]**

The setting data is backed up in the non-volatile IC memory.

**[Warm-up indication]**

After the power supply to the instrument is turned on, the PV Display indicates an input type, and SV Display indicates input range high limit value (for thermocouple, RTD inputs) or scaling high limit value (for Direct current and voltage inputs) for approximately 3 seconds, and control output is turned OFF.

**[Peak (or Bottom) value hold function]**

While the EXCEEDED indicator is lit, the peak value is maintained during high limit action, or Bottom (the lowest) value is maintained during low limit action.

Present measured value will be initialized after reset using the RST key or the external reset input function.

**[EXCEEDED indicator lighting duration time]**

EXCEEDED indicator lighting time can be measured and indicated by pressing the Mode (⊙) key in the PV/SV Display Mode.

Measurement range: 0:00 to 99:59 (Hour:Minute, Minute:Second)

Lighting time will be initialized to 0:00 after reset using the RST key or the external reset input function.

**[Transmission output]**

Converting the value (PV transmission, SV transmission) to analog signal every 0.25 seconds, outputs in current. (Default: PV transmission)

Resolution: 1/12000

Current: 4 to 20 mA DC (Load resistance: Max. 550 Ω)

Output accuracy: Within ±0.3% of each input span

**Accessories included:** Screw type mounting brackets: 1 set

Instruction manual (excerpt): 1 copy

**Accessories sold separately:** Terminal cover

## 8.2 Optional specifications

### A2 output (EV2 option)

Action: ON/OFF action  
Hysteresis: 0.1 to 100.0°C (°F), or 1 to 1000 (DC input) (Default: 1.0°C)  
Output: Relay contact 1a  
Control capacity: 3 A 250 V AC (Resistive load)  
1A 250V AC (inductive load  $\cos\phi=0.4$ )  
Electrical life: 100,000 cycles  
Minimum applicable load: 10 mA 5 V DC

### Serial communication (C5 option)

The following operations can be carried out from an external computer.

- (1) Reading and setting of the SV and each value
- (2) Reading of the PV and action status
- (3) Change of the functions

Cable length: Maximum communication distance: 1.2 km  
Cable resistance: Within 50  $\Omega$  (Terminators are not necessary, but if used, use 120  $\Omega$  or more on both sides.)  
Communication interface: EIA RS-485  
Communication method: Half-duplex communication start-stop synchronization  
Communication speed: 2400, 4800, 9600, 19200 bps (Selectable by keypad) (Default: 9600 bps)  
Parity: Even, Odd and No parity (Selectable by keypad) (Default: Even parity)  
Stop bit: 1, 2 (Selectable by keypad) (Default: 1)  
Communication protocol: Shinko protocol, Modbus ASCII, Modbus RTU (Selectable by keypad)  
Data format:

Communication protocol	Shinko protocol	Modbus ASCII	Modbus RTU
Start bit	1	1	1
Data bit	7	7	8
Parity	Even	Selectable (Even)	Selectable (No parity)
Stop bit	1	Selectable (1)	Selectable (1)

Data bit is automatically selected upon selecting the communication protocol. ( ): Basic set value





Number of units connectable: Maximum 31 units to 1 host computer

Communication error detection: Double detection by parity and checksum

# 9. Troubleshooting





If any malfunctions occur, refer to the following items after checking the power supply to the controller.

## 9.1 Indication

Problem	Presumed cause and solution
<p>“Fl EE” is indicated in the PV Display.</p>	<ul style="list-style-type: none"> <li>The controller is in the EXCEEDED indicator lighting duration time mode. Press the  key twice to revert to PV/SV Display Mode.</li> </ul>
<p>“Hi ” or “Lo ” is indicated in the PV Display.</p>	<ul style="list-style-type: none"> <li>Maximum or Minimum value is indicated. Press the  key once to revert to PV/SV Display Mode.</li> </ul>
<p>“- - - -” is flashing in the PV Display.</p>	<ul style="list-style-type: none"> <li>Burnout of thermocouple, RTD or disconnection of DC voltage (0 to 1 V DC) Replace each sensor. <b>How to check whether the sensor is burnt out</b> [Thermocouple] If the input terminals of the instrument are shorted, and if a value around room temperature is indicated, the instrument is likely to be operating normally, however, the sensor may be burnt out. [RTD] If approx. 100 Ω of resistance is connected to the input terminals between A-B of the instrument and between B-B is shorted, and if a value around 0°C (32°F) is indicated, the instrument is likely to be operating normally, however, the sensor may be burnt out. [DC voltage (0 to 1 V DC)] If the input terminals of the instrument are shorted, and if a scaling low limit value is indicated, the instrument is likely to be operating normally, however, the signal wire may be disconnected.</li> <li>Check whether the input terminals of thermocouple, RTD or DC voltage (0 to 1 V DC) are securely mounted to the instrument input terminals. Connect the sensor terminals to the instrument input terminals securely.</li> </ul>
<p>“- - - -” is flashing in the PV Display.</p>	<ul style="list-style-type: none"> <li>Check whether input signal wire for DC voltage (1 to 5 V DC) or Direct current (4 to 20 mA DC) is disconnected. <b>How to check whether the input signal wire is disconnected</b> [DC voltage (1 to 5 V DC)] If the input to the input terminals of the instrument is 1 V DC and if a scaling low limit value is indicated, the instrument is likely to be operating normally, however, the signal wire may be disconnected. [Direct current (4 to 20 mA DC)] If the input to the input terminals of the instrument is 4 mA DC and if a scaling low limit value is indicated, the instrument is likely to be operating normally, however, the signal wire may be disconnected.</li> <li>Check whether input signal wire for DC voltage (1 to 5 V DC) or Direct current (4 to 20 mA DC) is securely connected to the instrument input terminals.</li> <li>Check if polarity of thermocouple or compensating lead wire is correct.</li> <li>Check whether codes (A, B, B) of RTD agree with the instrument terminals.</li> </ul>
<p>The indication of PV Display is abnormal or unstable.</p>	<ul style="list-style-type: none"> <li>Check whether sensor input or temperature unit (°C or °F) is correct. Select the sensor input and temperature unit (°C or °F) properly.</li> <li>Sensor correcting value is not suitable. Set it to a suitable value.</li> <li>Check whether the specification of the sensor is correct.</li> <li>AC may be leaking into the sensor circuit. Use an ungrounded type sensor.</li> <li>There may be equipment that interferes with or makes noise near the controller. Keep equipment that interferes with or makes noise away from the controller.</li> </ul>

Problem	Presumed cause and solution
The PV Display keeps Indicating the value which was set in [Scaling low limit].	<ul style="list-style-type: none"> <li>Check whether the input signal wire for DC voltage (0 to 5 V DC, 0 to 10 V DC) and Direct current (0 to 20 mA DC) is disconnected.  <b>How to check whether the input signal wire is disconnected</b>  [DC voltage (0 to 5 V DC, 0 to 10 V DC)]  If the input to the input terminals of the instrument is 1 V DC and if the value corresponding to 1 V DC is indicated, the instrument is likely to be operating normally, however, the signal wire may be disconnected.  [Direct current (0 to 20 mA DC)]  If the input to the input terminals of the instrument is 1 mA DC and if the value corresponding to 1 mA DC is indicated, the instrument is likely to be operating normally, however, the signal wire may be disconnected.</li> <li>Check whether the input lead wire terminals for DC voltage (0 to 5 V DC, 0 to 10 V DC) or Direct current (0 to 20 mA DC) are securely mounted to the instrument input terminals.</li> </ul>
The PV Display is indicating "Err 1".	<ul style="list-style-type: none"> <li>Internal memory is defective. Contact our agency or us.</li> </ul>

## 9.2 Key operation

Problem	Presumed cause and solution
<ul style="list-style-type: none"> <li>Unable to set the SV, A1 value, etc.</li> <li>The values do not change by  or  key.</li> </ul>	<ul style="list-style-type: none"> <li>Set value lock (Lock 1 or Lock 2) is selected. Release the lock.</li> </ul>
The setting indication does not change within the input range even if the  or  key is pressed, and new values are unable to be set.	<ul style="list-style-type: none"> <li>Scaling high or low limit value in Setup mode may be set at the point where the value does not change. Set it to a suitable value while in the Setup mode.</li> </ul>

## 9.3 Control

Problem	Presumed cause and solution
Temperature does not rise.	<ul style="list-style-type: none"> <li>Sensor is out of order. Replace the sensor.</li> <li>Check whether the Sensor or control output terminals are securely mounted to the instrument input terminals. Ensure that the sensor or control output terminals are mounted to the instrument input terminals securely.</li> <li>Check whether the wiring of sensor or control output terminals is correct.</li> </ul>

- For all other malfunctions, please contact our main office or dealers.

# SHINKO TECHNOS CO., LTD. OVERSEAS DIVISION

Head Office : 2-5-1, Senbahigashi, Minoo, Osaka, Japan

URL: <http://www.shinko-technos.co.jp>

E-mail: [overseas@shinko-technos.co.jp](mailto:overseas@shinko-technos.co.jp)

Tel : +81-72-727-6100

Fax: +81-72-727-7006